



INSTRUCTIONS

- A.** The most important step in using the WHEELRITE is determining the vehicle's suspension position while on the ground, and simulating it when the existing wheel/tire combo is removed. To do this you will need 2 jacks or 1 lift and 1 jack and a measuring device. First while the car is on the ground, straighten the wheels and measure the distance between the center of the axle/hub and the fender edge closest to the tire. Record this measurement. Next, place 1 jack under the suspension to lift the tire off of the ground. After removing the existing wheel/tire combination, place the second jack under the chassis, and lift it to match the suspension position previously measured. You are now ready to make an accurate wheel/tire simulation.
- B.** Mount WHEELRITE to your vehicle hub using at least 3 lug nuts tightened by hand only. Make sure the WHEELRITE is centered on the hub and flat on the hub surface. If brake calipers cause interference, they must be removed.
- C.** Adjust the WHEELRITE to the desired diameter and tighten by hand. This adjustment may be limited by brake calipers and/or fender clearance.
- D.** Adjust the WHEELRITE to the desired backspacing using the numbered, telescoping bar closest to the clamping knob. Set the backspacing by aligning the indication with the desired number.
- E.** Bend the tire profile simulator wire over your chosen tire if available. Mark the tire where it would meet the wheel using a piece of tape. Insert the profile simulator wire into the small holes on the telescoping bar of the WHEELRITE. This will simulate a cross section of the tire allowing you to rotate the hub making sure that you have desired clearance.
- F.** You have now successfully used the WHEELRITE to determine your proper wheel specifications. It's that easy!

TO ACHIEVE ADDITIONAL MEASUREMENTS

To achieve wider measurements for offset or backspacing use the supplied nylon thumb screw and nylon nut to hold the two horizontal slide bars together. Then fasten the horizontal slide bars to the vertical slide bar using one of the supplied thumbscrews. A tape measure may be used to measure additional lengths. Please refer to fig.1 for pictorial views.

To achieve wheel diameters that are larger than 22" use the supplied extension bar which bolts to the vertical bar. When the extension bar is used, add 8" to the measurement displayed on the lower vertical bar. This setup will allow the tool to reach wheel diameters up to 30". When the extension bar is bolted to the vertical bar; the horizontal bars need to be bolted to the extension. Please refer to fig.3 for pictorial views.

NOTE: Use a clean rag with soapy water to Keep your WHEELRITE clean of dirt, grit, and debris usually found on the underside of most vehicles.



450 Business Park Road
Linn Creek, MO 65052
www.percyshp.com

WHEELRITE™

WHEEL AND TIRE SIMULATOR

Part#

01201 15-20" Diameter 4 & 5 lug

Wheel width measurements from 6" to 11+"

Wheel width diameters from 15" to 30"

Identify 98mm to 130mm on four or five lug bolt pattern

Identify 4" - 5.5" on four or five lug bolt pattern

Thank you and congratulations on purchasing the best problem solving tool for measuring wheels ever invented!

There has always been a problem of figuring out just how much tire and wheel can be stuffed into a wheel well without rubbing on the inner or outer fender. The WHEEL-RITE makes all of these problems and headaches yesterday's news. Percy's has engineered a wheel measurement tool that allows anyone to find the correct offset, backspace, diameter, width, and tire profile on the first attempt.

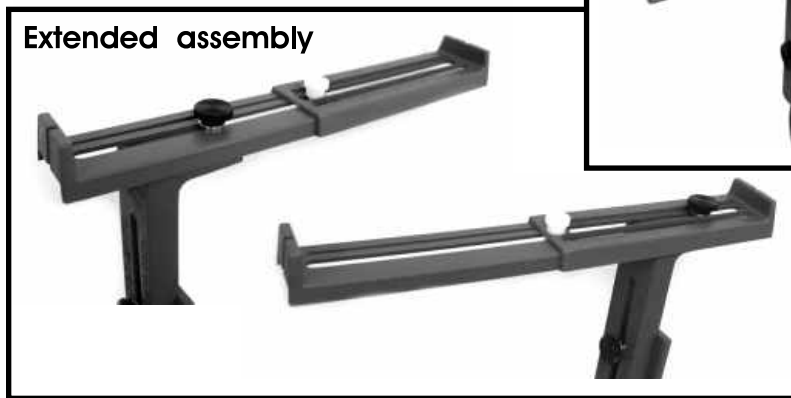
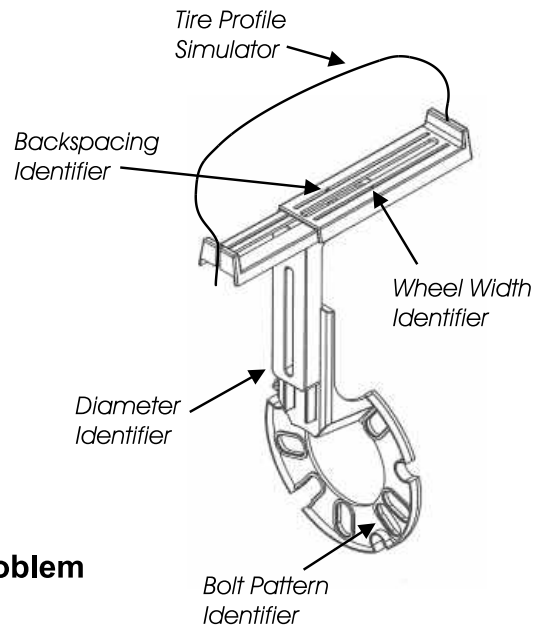

Fig. 1



Fig. 3



450 Business Park Road
Linn Creek, MO 65052
www.percyshp.com

THE WHEELRITE INCLUDES

- 1-Wheelrite wheel and tire simulator
- 3- 1/4x20 thumb screws
- 3- 1/4x20 nuts
- 3- 1/4 washers
- 1- Nylon thumb screw
- 1- Nylon nut
- 1- Wire
- 1- Instruction sheet

PATENT APPLICATION PENDING